

WELCOME TO THE
PUBLIC ARTS COMMITTEE'S
REGULAR MEETING



CITY OF
FLORENCE

October 23, 2023
Florence City Hall

CALL TO ORDER – ROLL CALL

PUBLIC COMMENT

This is an opportunity for members of the public to bring to the committee's attention any item not listed on the agenda. Comments will be limited to three (3) minutes per person, with a maximum time of 15 minutes for all items.

There are no verbal Public Comments for today's meeting. If written comments were received, they will be sent to the committee and uploaded to the website.

CONTINUING EDUCATION

ARTS & ECONOMIC PROSPERITY STUDY



Food, Music, Prizes!

THE ARTS

MEAN BUSINESS

You are invited to a
Community Celebration
to see how much the
arts contribute to
local businesses.

November 8th
4pm to 5:30pm
Florence Events Center



Come see what
you told us: Data
from almost 1,000
surveys
completed at
local events will
be revealed.



TRAVEL  OREGON



ARTS & HUMANITIES MONTH

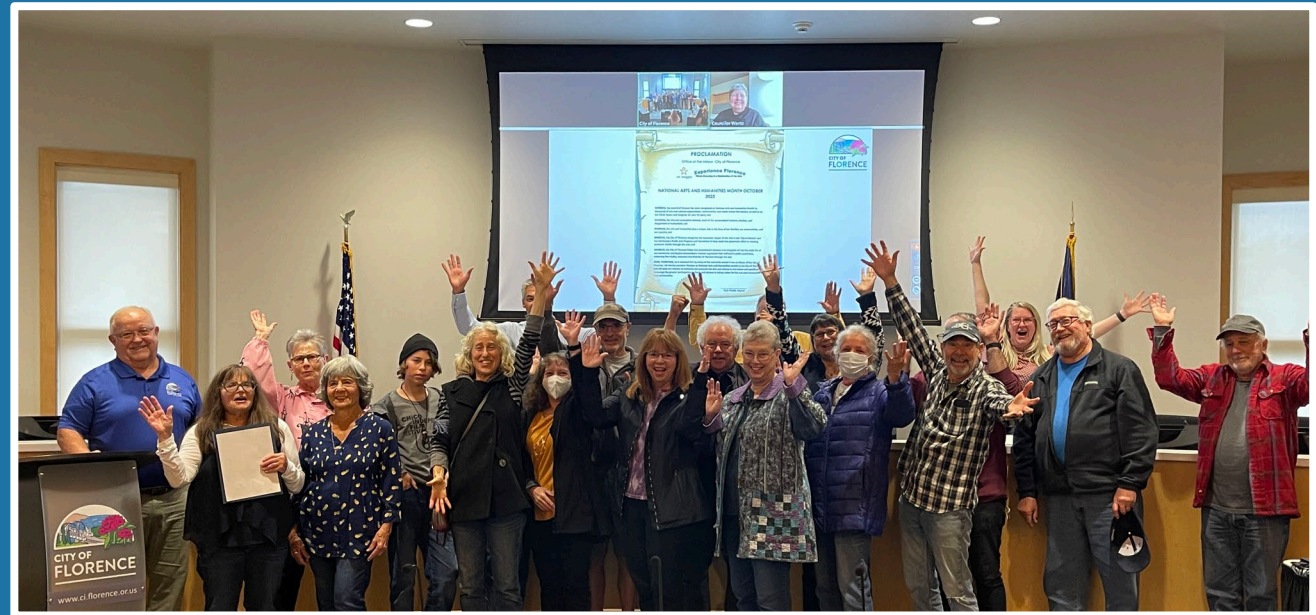

The Florence Public Arts Committee accepted the 2023 National Arts & Humanities Month proclamation from Mayor Rob Ward on October 16 during the Florence City Council meeting

**ART EXPOSED
2024-2026 EXPANSION**

ART EXPOSED GALLERY – INTRODUCTION

- The Art Exposed Rotating Outdoor Art Gallery Program is a dynamic bi-annual rotation of public art that enhances the livability of our community, creates a unique sense of place, and enhances community identity, while also providing an increased economic impact for visitors and residents.
- Art Exposed offers the community a chance to view interesting, “fresh” artwork every two years at a low cost, while providing artists with an opportunity to display and sell their work to a wide audience.
- Learn more about Art Exposed at <https://www.ci.florence.or.us/bc-pac/art-exposed-florences-rotating-outdoor-art-gallery>

ART EXPOSED

Florence's Rotating Outdoor Art Gallery



ART EXPOSED EXPANSION – PROCESS

- In the adopted 2023-2025 FURA Biennial Budget, the Urban Renewal Agency approved the placement of art through City of Florence Public Art Program's Art Exposed Rotating Outdoor Art Gallery. These artworks will be placed throughout the ReVision Florence corridor on Highway 101.
- The Florence Public Arts Committee will operate ReVision Art Exposed. This includes:
 - Describing each location and the unique specification for a call-to-artists through Call for Entry (CaFÉ)
 - Marketing the call to local, regional, and state artists
 - Working in a subcommittee and then the greater committee to review the applications and eventually vote on finalists, all in public meetings
- City staff will notify the artists and then negotiate contracts and timelines for installation
 - Public Works, Community Development, Administration, and other City staff are part of the process

ART EXPOSED EXPANSION – SITE CHOICES

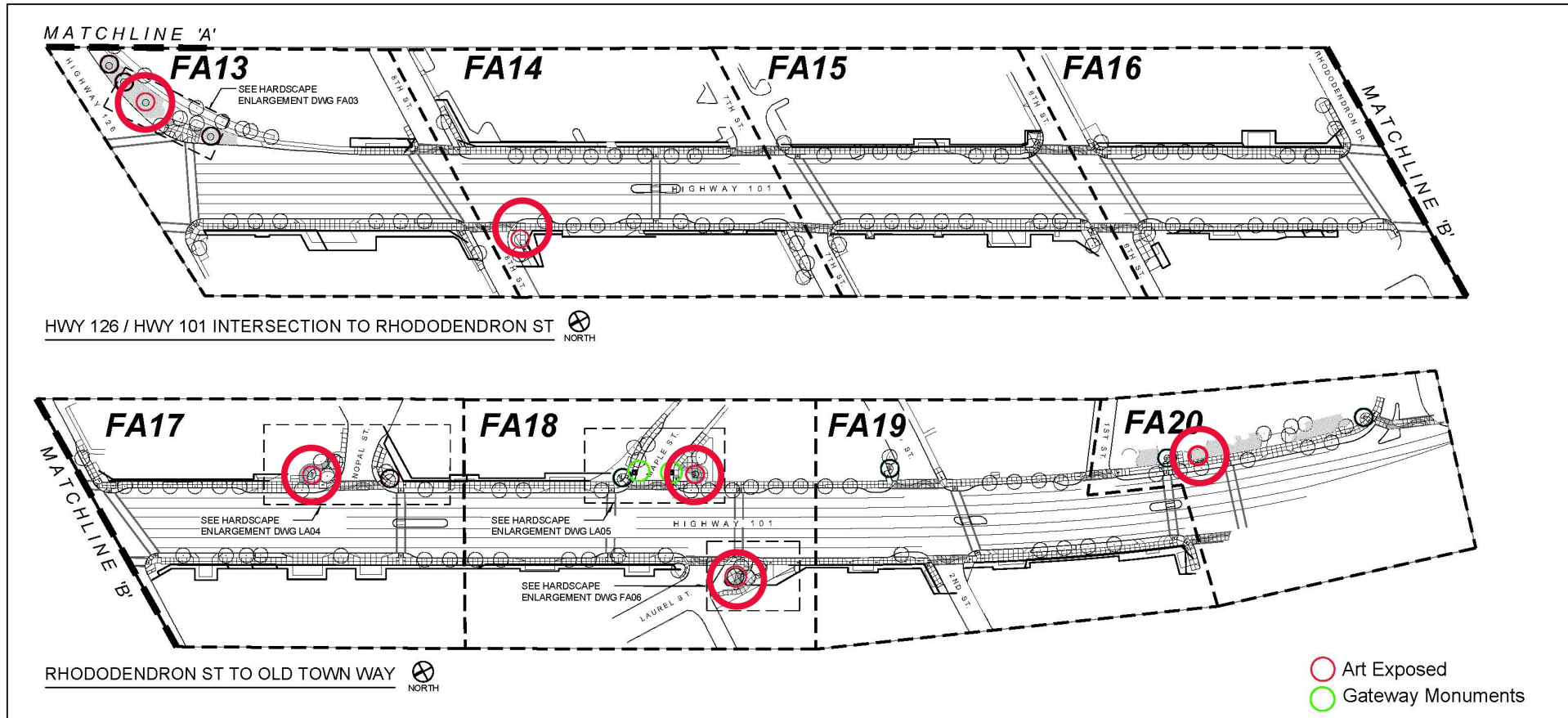

ART EXPOSED EXPANSION – SITE CHOICES

Selected Sites (from north to south)

1. Highway 126

Intersection

2. 8th Street Corner

3. Nopal Street

4. Maple Street

5. Laurel Street

6. 1st Street



ART EXPOSED EXPANSION – SITE OPTIONS

I. Highway 126 Intersection (SE Corner)

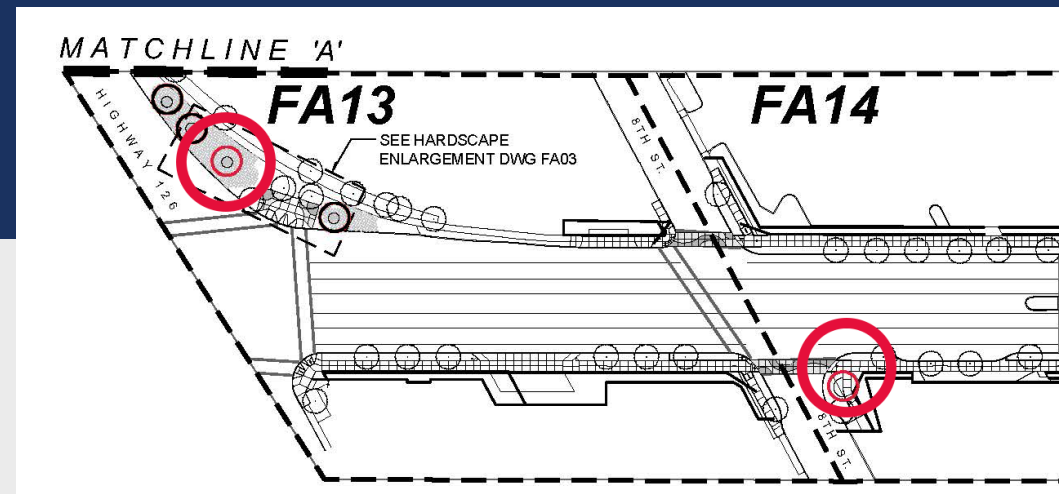

ART EXPOSED EXPANSION – SITE OPTIONS

2. 8th Street (SW Corner)

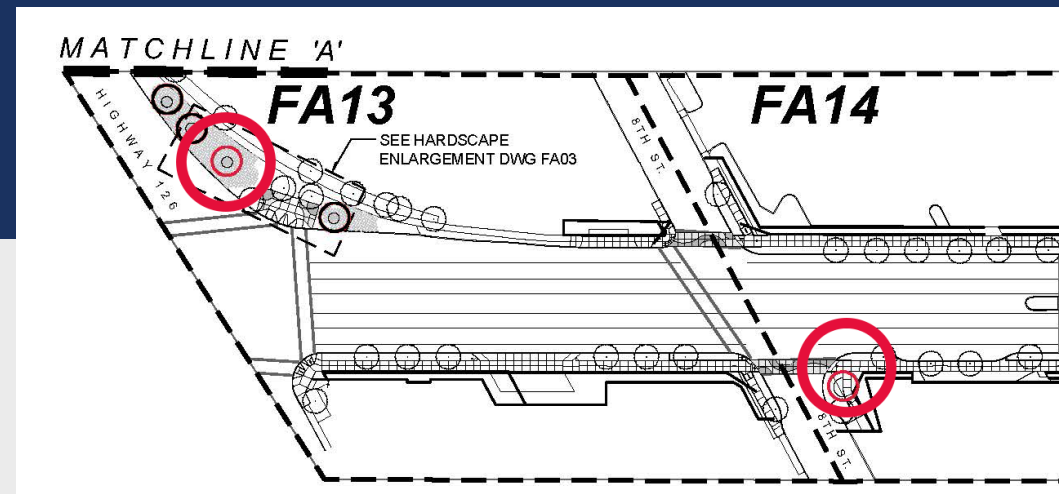

ART EXPOSED EXPANSION – SITE OPTIONS

3. Nopal Street

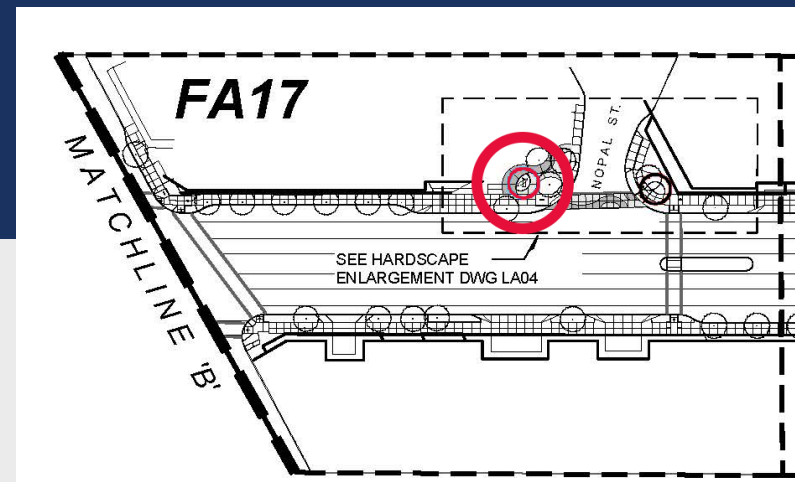

ART EXPOSED EXPANSION – SITE OPTIONS

4. Maple Street

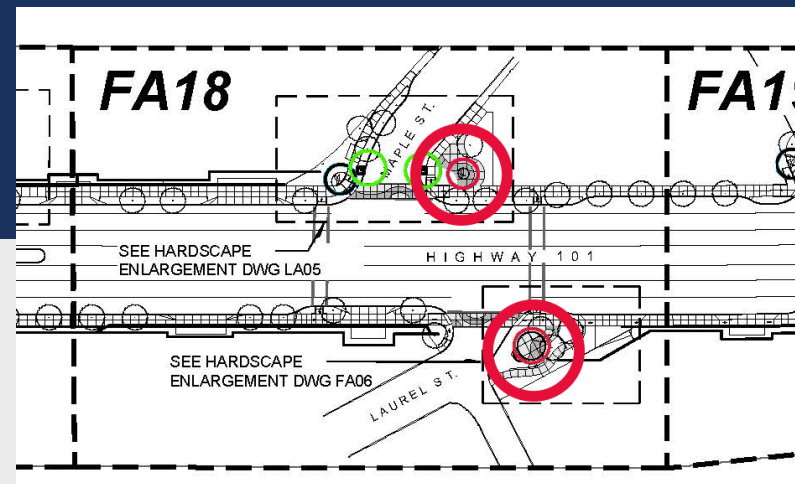

ART EXPOSED EXPANSION – SITE OPTIONS

5. Laurel Street

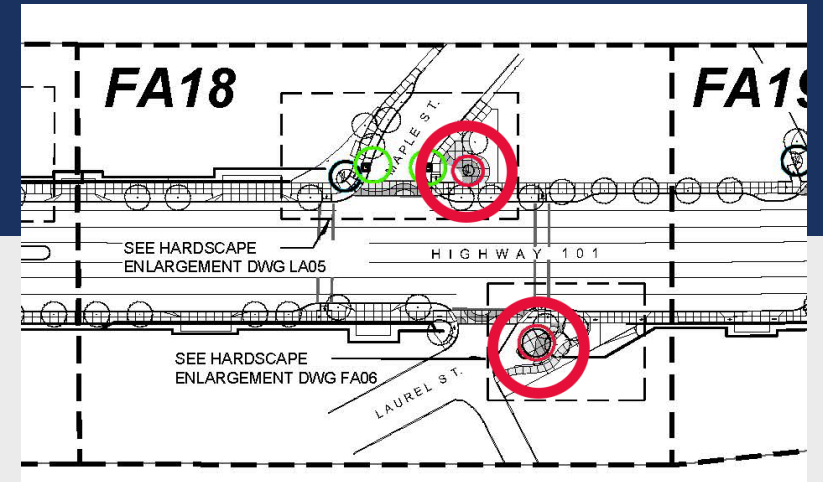

ART EXPOSED EXPANSION – SITE OPTIONS

6. 1st Street – Old Town Inn

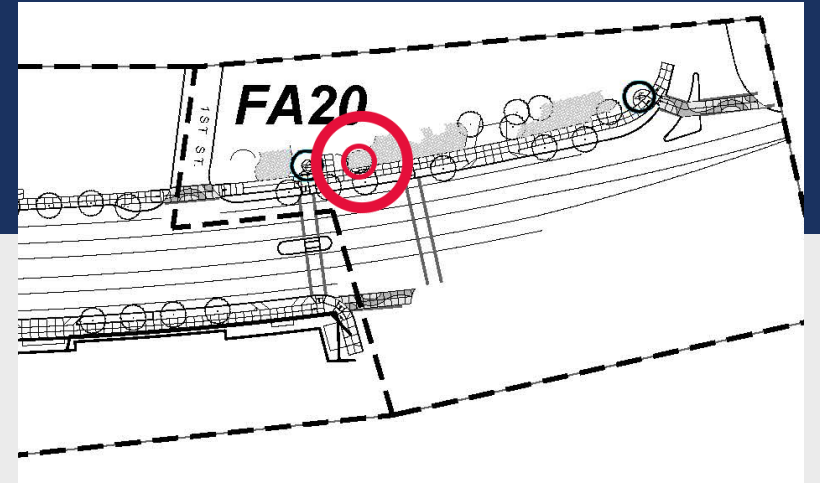

ART EXPOSED EXPANSION – SITE OPTIONS EXISTING PLINTHS

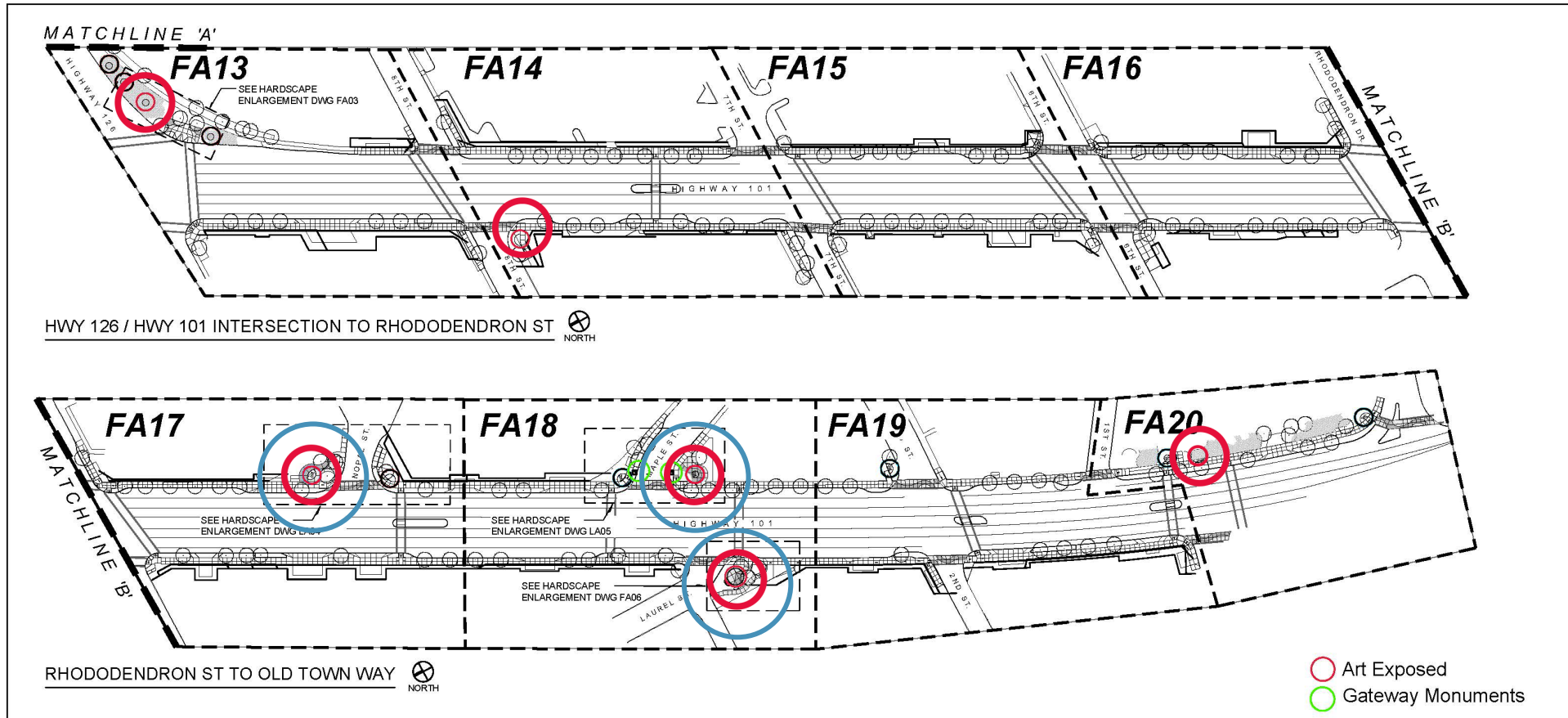

Existing
poured
concrete
plinths

ART EXPOSED EXPANSION – TIMELINE

Month	Task
September 2023 - October 2023	<ul style="list-style-type: none">● Review 2024-2026 Program and discuss FURA's needs● Create Art Exposed Subcommittee● Finalize Call-for-Artists and approve for release in late October
November 2023 – December 2023	<ul style="list-style-type: none">● Manage call-to-artists through https://www.callforentry.org/● Market call-to-artists for local artists, plus statewide, national, and international artists● Subcommittee narrows applicants

ART EXPOSED EXPANSION – TIMELINE

Month	Task
January 2024	<ul style="list-style-type: none">● Special public meeting for PAC to review submissions and select 2-3 finalists for each space● Solicit public input on finalists for each location● PAC reviews public input and finalizes selections for each space at January regular meeting
February 2024 – March 2024	<ul style="list-style-type: none">● Provide report to FURA Board● Artist communications and logistics● Artists / City negotiate contracts● Marketing plan for installation is created

ART EXPOSED EXPANSION – TIMELINE

Month	Task
April 2024	<ul style="list-style-type: none">● New Art is installed in April 2024● Urban Renewal Board and Public Arts Committee invited● Marketing plan for installation is executed
Spring 2024 – Summer 2024	<ul style="list-style-type: none">● Celebrate the project with Walking Tour, engagement over Rhody Days, etc.● Continue to market the art

ART EXPOSED EXPANSION – CONSIDERATIONS

- Staff reviewed proposed locations within the ReVision corridor with Urban Renewal
 - The plan is to use the three existing plinths and two/three other spots
 1. Highway 126 Intersection
 2. 8th Street (SW Corner)
 3. Nopal Street
 4. Maple Street
 5. Laurel Street – Crescent Plinth
 6. 1st Street – Old Town Inn
- Urban Renewal's desired themes to include in the Call to Artists would be:
 - Bright colors – colorful and vibrant
 - Coastal colors and themes if possible
 - Consideration for traffic safety (not too shiny)
 - Wow! Factor
 - Substantial scale

ART EXPOSED EXPANSION – CALL FOR ART

Legal Agreement:

All artists must be 18 years of age to be eligible to apply. The chosen artists will be approved by the City of Florence based on the submitted images, application materials, proposals and proposal presentations. The City of Florence approves art concepts, project scope and budget, thereby allowing the artist creative license within the established project plan. The City of Florence reserves the right to reject any and all applications. If a proposal is selected, the selected artists will be expected to sign a contract with the City of Florence. The Contract will include the artist taking responsibility for installing the artwork and granting the City ownership of the artwork for the length of the contract.

ART EXPOSED EXPANSION – CALL FOR ART

Introduction:

The City of Florence is pleased to invite emerging, mid-career, and established artists to submit work to the Public Art Committee's program, Art Exposed, a rotating outdoor art gallery. Florence is offering artists an opportunity to display their work on a .7-mile stretch of Highway 101 for a two-year period.

Florence is host to over one million visitors a year, and the busy Oregon Coast Highway leads people to the popular restaurants, galleries, and shops throughout the area. The Art Exposed program generates community pride, provides artists a display with high visibility, stimulates conversations about art, promotes Florence as a destination to view public art, and creates a sense of place for our community members and visitors.

The City of Florence's Public Arts Committee is a dedicated group of volunteers composed of local artists, business owners, and long-term supporters of the arts. The Committee, since its inception in 2015, has installed 23 pieces of art, including a large-scale mural at the Highway 126 Gateway entrance to Florence.

Currently, the Art Exposed program has eight pieces of art that are on display in Historic Old Town. In this call-to-artists, the City of Florence will be expanding the program to include six locations on the highway. Each location has specific dimensions and particular requirements.

ART EXPOSED EXPANSION – CALL FOR ART

While on display, the pieces are for sale to locals, as well as Florence visitors. It has been one of the most successful programs of the Public Arts program, providing members of the local artist community and national and international artists with an opportunity to display their art. The City has been successful in selling the pieces on display.

Artists are offered a stipend of \$1,500 to provide their work for a maximum of two years. During the two-year period, the art would be offered for sale, with the City of Florence keeping a portion of the sale proceeds to support the future of the Public Arts Program. The artist also has the opportunity to replace any sold art with a new piece during the two-year time frame.

General Project Information:

- Six (6) locations for art have been selected by the Public Arts Committee, located on Highway 101 between the Siuslaw River Bridge and the Highway 126 intersection in Florence. Details of the locations are listed in the *Location Information* section below and visuals are included in the downloadable Supplemental Materials document.
- Artists are allowed to submit one entry for each of the 6 locations.
- Each piece submitted will be part of a new application, and a \$25 fee will be applied.
- Each artist will be provided a stipend for their piece of \$1,500.00.

ART EXPOSED EXPANSION – CALL FOR ART

- Art displayed as part of the Art Exposed program must be available for sale to the public and be available for two years from date of installation.
- Should art be purchased prior to the completion of the contract timeline, the artist shall be given first opportunity to replace art with a suitable piece to be approved by the Public Arts Committee. If the artist chooses not to replace the work, the Committee will decide whether to open the space to a new artist through a new call-to-artist.
- The City of Florence provides bases for the art to be installed upon (Pictures and descriptions of the bases are available in the Supplemental Materials Document) and Public Works crews are available to support installation with direction of the artist.
- All costs associated with transportation of the artwork to Florence, Oregon, will be the responsibility of the artist.
- All artwork must be the original design and artwork of the artists and suitable to be viewed by all ages.
- All artists must be over the age of 18 to apply.
- Selected artwork will be scheduled to be installed in April 2024. The schedule of installation will be adjusted based on location and artist, depending on the situation.
- [The deadline for submission is December 11, 2023, at 11:59 p.m. MST \(9:59 p.m. PST\)](#)
- The Committee determines by vote which location is most appropriate for the submitted piece, while also taking into account the artist's preference in location.

ART EXPOSED EXPANSION – CALL FOR ART

Eligibility and Design Guidelines:

- All artists must be over eighteen (18) years old to be eligible
- There is no required theme for most locations; creativity and innovation of designs are encouraged.
- Artwork must submit photographs of the specific art that is being entered. Work-in-progress must be at least 75% completed and photographs of the work in progress must be submitted. Mock ups, models, drawings, or concepts are not accepted for this Call.
- Entries must be the original design and artwork of the entrant. Designs must not include any breach of intellectual property, trademarks, brands, business names, corporate or organizational brandings or imagery of violence, drugs and alcohol.
- Entries must be suitable for viewing for all ages.
- Artwork submitted may not be used for advertisement or to promote a business, product, or viewpoint.
- Artists may submit work on their own or as part of a team.
- Artwork can be of any medium but must be able to withstand coastal weather conditions including wind and seasonal rain, as well as resistance to theft, vandalism, excessive maintenance and repair costs.
- **Artwork cannot exceed 500 pounds in total weight.**

ART EXPOSED EXPANSION – CALL FOR ART

- Artwork must include a thirty-six-inch (36") diameter plate on the bottom with four (4) one-inch (1") diameter bolt holes to accommodate 3/4th inch bolts on 22 inch spacing to be used to attach to the base provided by the City of Florence for installation (See Supplemental Materials document and diagram entitled Art Base Installation Information).
- Each work will be evaluated to require that it does not present a hazard to public safety and must conform to ADA standards.

Submission Information and Requirements:

- When submitting, artists must specify the location in which they are submitting their piece of art to be installed at (Please note that all locations have unique requirements, including thematic preferences)
- Artists are allowed to submit one piece per location
- There is a \$25.00 entry fee for each artist

ART EXPOSED EXPANSION – CALL FOR ART

Evaluation Criteria:

Art submitted to the Art Exposed program will be evaluated on five criteria categories:

1. Visual Impact – Overall Quality
 - a. A perfect score will be given to an artist who has uniquely organized the art elements and content and has created a striking and memorable piece of work. If selected, this project has the power to “wow” the viewer.
2. Interpretation & Criteria – Completeness / Effort
 - a. A perfect score will be given to an artist who shows unique and creative interpretation of the project and was continued until it was complete as possible. Effort was far beyond what was required, with great attention to detail.
3. Composition & Design – Organization
 - a. A perfect score will be given to a piece of art that shows and effectively utilizes knowledge of the elements and principles of design. The design effectively fills the entire space.
4. Craftsmanship – Made with Skill of Mediums and Overall Neatness
 - a. A perfect score will demonstrate a mastery of skill and a clear understanding and application of specific medium qualities. The design is beautiful and complete.
5. Adherence to Design Criteria & Eligibility Guidelines
 - a. A perfect score shows that all criteria of the call-to-artists have been met. Artists has demonstrated the best example of following directions for assignment.

ART EXPOSED EXPANSION – CALL FOR ART

Location Information:

The 2024 Art Exposed Expansion adds six new pieces of public art to the City of Florence, spreading out from the established Historic Old Town Rotating Outdoor Art Gallery up to the ReVision Corridor on Highway 101. The City of Florence and the Florence Urban Renewal District recently completed a multi-million-dollar streetscape project that expanded sidewalks, repaved Highway 101, and overall made the Highway district much more walkable and friendly for pedestrians. The expansion of Art Exposed will bring colorful art to a .7-mile stretch of the highway at the entrance to the City of Florence.

- **Location #1 – Highway 126 Intersection**

This location is at the southeast corner of the intersection between Highway 126 and Highway 101. This corner will be seen by millions of people every year as they stop in Florence or continue up and down the highways. The piece will be close to lodging and foot traffic in town and visible from Florence’s “Stitching Time, Weaving Cultures” mural. Uniquely, it is near several traffic control devices, including stop lights and turning signs. All these will be considered as art is reviewed.

ART EXPOSED EXPANSION – CALL FOR ART

- **Location #2 – 8th Street Corner**

On the west side of Highway 101 is a small area at the south corner of 8th Street. This landscaped area will surround the chosen art with native greenery and encourage pedestrians to walk the ReVision Corridor. Note: This site may remain open if submissions do not fulfill the Public Arts Committee's expectations.

- **Location #3 – Nopal Street**

This location features a paved seating area and one of the original large-scale plinths of the ReVision Corridor. Nopal Street is one of the entrances into Historic Old Town Florence and accesses the Port of Siuslaw Boardwalk and parking areas. Additionally, the site is part of the Highway and Antiques Districts, with local shops in the same block.

ART EXPOSED EXPANSION – CALL FOR ART

- **Location #4 – Maple Street**

This location welcomes visitors driving and walking at the entrance to the Historic Old Town district. It offers an ideal location near the Florence Area Chamber of Commerce and the busy Florence Visitors Center. The center is visited by over a half a million people every year who are looking for things to do around town and the surrounding area. This location includes a plaza with a seating area, along with the nearby Maple Street Florence Old Town Gateway Monuments. Art Exposed has one existing piece of art in the same block: “Goddess” by Lucy Ruth Wright Rivers.

- **Location #5 – Laurel Street**

The Laurel Street Plaza features a crescent-shaped plinth and a seating area at the southern end of the ReVision Corridor. It abuts neighboring businesses and has a view of Florence City Hall, the Siuslaw River Bridge, and is directly across the street from the Maple Street Art Exposed location.

- **Location #6 – 1st Street**

The southernmost location for the Art Exposed Expansion will be the first piece of art welcoming people into the City of Florence as they exit the Siuslaw River Bridge. This location features a sitting area and a view of the historic bridge and neighboring businesses in the Urban Renewal District.

ART EXPOSED

Florence's Rotating Outdoor Art Gallery

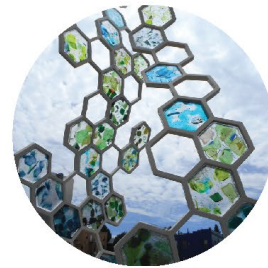

SUBCOMMITTEE CHECK-INS

Outreach/Marketing

Art Exposed

Art Inventory/Maintenance

CHAIR REPORT

MEMBER REPORT

Updates on the arts and culture events, programs, demonstrations, and celebrations of the Florence area and surrounding communities

STAFF REPORT

NEXT MEETING DATES

Let's check in on how our morning meetings work!

TENTATIVE MEETING CALENDAR

All PAC Meetings are held on the 4th Monday of the Month. Meetings are held in person at Florence City Hall unless otherwise indicated.

Date	Time	Description
November 8, 2023	4 to 5:30 p.m.	Florence Arts and Economic Prosperity Study Community Celebration
November 27, 2023	4 p.m.	PAC Meeting
December 2023	--	Subcommittees will meet

THANK YOU

Experience *Florence*

WHERE EVERY DAY IS A CELEBRATION OF THE ARTS

PUBLIC COMMENTS – 3 MINUTE COUNT DOWN TIMER

2 Minutes Left

1 Minute Left

30 Seconds Left

Time is Complete