

Clare Kurth

From: Michael Schick <chief@wlfea.org>
Sent: Tuesday, May 30, 2023 4:55 PM
To: Clare Kurth; John Pitcher; MWagner@cencoast.com; BAUMGARTNER Douglas G
Subject: RE: PUD / Subdivision Application at 37th and Oak

Follow Up Flag: Follow up
Flag Status: Flagged

Clare,
 Preliminary plan looks good for street width and proposed location and shape/size of emergency vehicle turnaround. My questions about hydrants, water supply, and automatic sprinklers can wait.

D103.1 Access road width with a hydrant. Where a fire hydrant is located on a fire apparatus access road, the minimum road width shall be 26 feet (7925 mm), exclusive of shoulders (see Figure D103.1).

D103.4 Dead ends. Dead-end fire apparatus access roads in excess of 150 feet (45 720 mm) shall be provided with width and turnaround provisions in accordance with Table D103.4.

**TABLE D103.4
 REQUIREMENTS FOR DEAD-END
 FIRE APPARATUS ACCESS ROADS**

LENGTH (feet)	WIDTH (feet)	TURNAROUNDS REQUIRED
0–150	20	None required
151–500	20	120-foot Hammerhead, 60-foot “Y” or 96-foot-diameter cul-de-sac in accordance with Figure D103.1
501–750	26	120-foot Hammerhead, 60-foot “Y” or 96-foot-diameter cul-de-sac in accordance with Figure D103.1

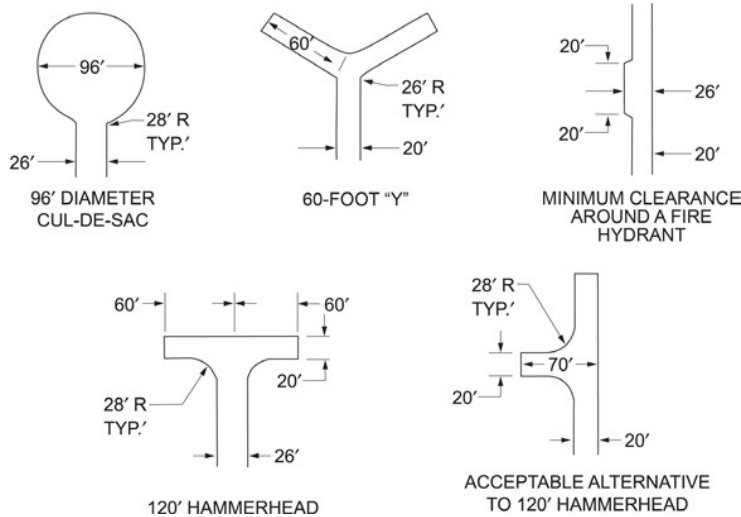

Do you know what the planned height of these buildings will be? Over 30 feet and I will want to look at requiring access for an aerial apparatus. The current access may be adequate.

**SECTION D105
 AERIAL FIRE APPARATUS ACCESS ROADS**

D105.1 Where required. Where the vertical distance between the *grade plane* and the highest roof surface exceeds 30 feet (9144 mm), *approved* aerial fire apparatus access roads shall be provided. For purposes of this section, the highest roof surface shall be determined by measurement to the eave of a pitched roof, the intersection of the roof to the

exterior wall, or the top of parapet walls, whichever is greater.

D105.2 Width. Aerial fire apparatus access roads shall have a minimum unobstructed width of 26 feet (7925 mm), exclusive of shoulders, in the immediate vicinity of the building or portion thereof.

From: Clare Kurth <clare.kurth@ci.florence.or.us>

Sent: Tuesday, May 30, 2023 12:08 PM

To: Michael Schick <chief@wlfea.org>; John Pitcher <john.pitcher@ci.florence.or.us>; MWagner@cencoast.com; BAUMGARTNER Douglas G <Douglas.G.BAUMGARTNER@odot.oregon.gov>

Subject: PUD / Subdivision Application at 37th and Oak

Hello,

The City of Florence has received an application for a PUD / Subdivision of 25 individual lots with single family attached units at 37th and Oak St. This is scheduled for a public hearing with the Planning Commission on June 13th. Please review the application [HERE](#) and provide any comments by June 5th.

In addition to the 25 units being proposed, 37th St will be extended west towards Florence Golf links, an emergency vehicle turn around is included, and a stub for future development of E Myrtle Loop.

Please let me know if you have any questions or need additional information.

Clare Kurth (She/Her)

Assistant Planner | City of Florence

clare.kurth@ci.florence.or.us

City of Florence

250 Hwy 101

Florence, OR 97439

Follow Us! [City Website](#) | [Facebook](#) | [Twitter](#) | [Instagram](#) | [Vimeo](#)

Clare Kurth

From: Michael Schick <chief@wlfea.org>
Sent: Friday, June 2, 2023 1:25 PM
To: Clare Kurth
Subject: RE: Myrtle Glen

Clare,

Thanks for the additional information! Those hydrant locations will be fine. If my calculations are correct it looks like the largest four plex will come in at 5,716 ft². That requires a minimum fire flow of 2,000 gpm for 2 hours (OFC Table B105.1(2)).

From: Clare Kurth <clare.kurth@ci.florence.or.us>
Sent: Thursday, June 1, 2023 5:20 PM
To: Michael Schick <chief@wlfea.org>
Subject: Myrtle Glen

Chief Schick,

Attached is the sheet that shows the fire hydrant locations. They are proposing 2, one at the west end of 37th and one at the intersection of 37th and East Myrtle Loop. The applicant said they plan on having the buildings ~27 feet high.

Please let me know if you have other questions about this PUD/Subdivision.

Clare