

**Florence City Hall**  
 250 Highway 101  
 Florence, OR 97439  
[www.ci.florence.or.us](http://www.ci.florence.or.us)

**Finance Department**  
 541-997-3436

**Building/Planning**  
 541-997-8237

**Inspection Request**  
 541-997-2141 xt. 3

**City Recorder**  
 541-997-3437

**City Manager's Office**  
 541-902-2182

**Public Works**  
 541-997-4106

**Police Department**  
 541-997-3515

**Florence Events Center**  
 541-997-1994

**Inside this issue:**

"If I were Mayor..." 1  
 Contest Winner

Employee Spotlight 2

Vegetation Can 2  
 Cause Visibility  
 Problems

Understanding Your 3  
 City Utility Bill

Rates for Trash 4  
 Collection Adjusted

City Calendar 5



Siuslaw Bridge photo courtesy of Joshua Greene, © 2011 All Rights Reserved

June 2012

## Jordan Knapp Winner of 2012 "If I were Mayor..." Poster Contest

**S**iuslaw Elementary School second-grader

Jordan Knapp was announced as the winner of the 2012 "If I were Mayor..." poster contest during a ceremony at the Boys and Girls Club Tuesday, May 15. Florence Mayor Phil Brubaker presented Knapp with a certificate, City of Florence pin and a \$25 gift card for his winning poster "If I were Mayor, I Would Go Back in Time!!!"

Knapp's winning entry was selected by Mayor Brubaker and the



**Mayor Phil Brubaker awards Jordan Knapp a certificate, gift card and City pin during a ceremony held May 15th.**

Florence City Council from more than 40 posters turned in by the Boys and Girls Club of Western Lane County. Sponsored by The City of Florence, Oregon Mayors Association and Oregon Afterschool for Kids, the "If I were Mayor..." contest was held in conjunction with the 2012 Oregon Mayors Association's annual conference which is July 26 to 28 at Driftwood Shores.

Visit Florence City Hall to view Knapp's winning poster or visit the City web site at [www.ci.florence.or.us](http://www.ci.florence.or.us) for a photo gallery of all the entries.



**Above left: Mayor Brubaker takes questions from Boys and Girls Club members. Above right: Jordan Knapp's winning entry "If I were Mayor... I Would Go Back in Time!!!"**

# Employee Spotlight

## Wastewater Supervisor Rick Mumpower

Wastewater Treatment Plant Supervisor Rick Mumpower is the picture of consistency and longevity. For 36 years, Rick has worked for the City of Florence, a testament not only to his value as an employee, but also to his ability to change and adapt through ever-evolving technologies.

In his free time, Rick is an avid outdoorsman. "I do an awful lot of huntin' and fishin'," says Rick, who is known as an accomplished bow hunter. He was also a competitive volleyball player for more than 30 years, playing on sand, grass and in gyms.

"Volleyball is one of the best lifetime sports there is, in my opinion," said Rick.

Above all else, Rick is most proud of his daughter McKenzie, a third-year student at Southern Oregon University, where she is studying to be a teacher.



Wastewater Supervisor Rick Mumpower is one of the longest tenured employees, having worked at the City of Florence for almost four decades.

### What do you like most about being the Wastewater Treatment Plant Supervisor?

"I like the variety that comes with operating a lot of mechanical equipment. Treatment Plant operators commonly deal with everything including plumbing, electricity, welding, pump repairs, building maintenance and landscaping."

### Proudest moment at the City?

"That would be when the new treatment plant came on line. Just knowing that we had good, new equipment and plenty of capacity was a relief."

### Strangest request you've had as a Wastewater Supervisor?

"A woman called and asked if I could try to find her \$7,000 ring that had went down the drain. We never found it."

## Vegetation Can Cause Visibility Problems on Right-of-Ways

Submitted by Code Enforcement

Concern from area residents and an increase in observed violations has prompted the City of Florence to put out this educational release regarding vegetation that causes visibility and passage problems on City right of ways, including streets and sidewalks.

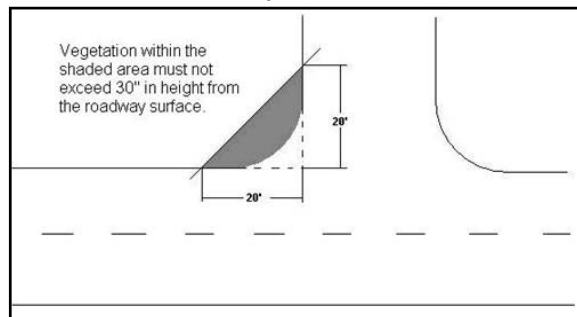

Under Florence City Code, vegetation shall not obstruct clear vision at street and driveway intersections. The defined "Clear Vision Area" can be described as a triangle extending inward 20-feet on each street from where both curb lines would come to a point if the curb was not

rounded. See the diagram to the left for further explanation.

In addition to visibility concerns, vegetation is often observed growing onto or over sidewalks and streets, sometimes to the extent where it limits free passage of vehicles and/or pedestrians. City Code stipulates that

no vegetation should hang over a sidewalk at a height of any less than 8-feet, and a street at a height of any less than 13-feet, four-inches.

All residents should take the time to inspect their property for either of these violations.



# Understanding Your City of Florence Utility Bill

Submitted by Finance Department

City of Florence residents receive a utility bill once a month for services provided for the previous month. It is a common misconception that this is a "water bill", but it is much more than just a bill for water. The City of Florence is committed to providing residents and businesses with not only top quality water service, but also sewer, stormwater, well-rehab and street services. Like anything else, there are costs related to providing these services. Each year as part of the budget process, City Management and the Budget Committee discuss whether fee increases are warranted (due to increases in the cost of supplies, personnel and planned capital projects) in order to maintain and improve our systems and infrastructure. In order to cover costs of operations and utility enterprise debt service, the City collects these fees by way of a monthly utility bill.

The City of Florence budget for fiscal year 2013, as approved by the Budget Committee, includes increases in rates for Water (4%) and Sewer (15%) service charges as well as revising the Street Light Fee (to be named Street Maintenance Fee) and increasing it to \$5 per dwelling unit. If approved by the City Council at the June 4<sup>th</sup> City Council meeting, the rates will take effect July 1, 2012. The proposed rates and fee adjustment amount to an increase of approximately \$10 per month for a *typical*\* Florence Resident.

Proposed fees are illustrated below in the form of a utility bill for the month ending July 31, 2012:

CITY OF FLORENCE - UTILITY BILL						
SERVICE ADDRESS			ACCOUNT NO.	BILLING DATE	DUE DATE	
1111 ANY STREET, FLORENCE, OR			555111.XX	07/31/12	08/15/12	
METER READINGS	PREVIOUS READ	CURRENT READ	CONSUMPTION	SERVICE PERIOD FOR METER READINGS	FROM	TO
	1100	1800	700		07/1/12	07/31/12
DESCRIPTION OF SERVICES					AMOUNT	
Previous Balance					79.38	
Payment - Thank You					(79.38)	
Water					1	29.32
Sewer					2	48.27
Storm Water					3	6.20
Well Rehabilitation					4	1.00
Street Maintenance Fee					5	5.00
<i>Disclosure: This is an example bill for an average residential customer using rates effective July 1, 2012. For illustration purposes only. Please contact the City of Florence Utility Department at (541) 997-3436 for information pertaining to your account.</i>				Due Date	AMOUNT DUE	
				8/15/2012	89.79	

Rate Table Legend for Residential Customers with comparison of old and new rates effective 7/1/12	
1	Water: Base Fee [ \$16.09 <del>\$15.47</del> ] + variable rate [ (700 cubic feet * \$0.189 <del>\$0.182</del> ) = \$13.23 ] = Total \$29.32 <del>\$28.24</del>
2	Sewer: \$48.27 <del>\$41.97</del> (Fixed cost)
3	Stormwater Fee: \$6.20 (Fixed cost based on square footage of permeable surface)
4	Well Rehabilitation Fee: \$1.00 (Fixed cost)
5	Street Maintenance Light Fee: \$5.00 <del>\$2.00</del> (Fixed cost)

\*Typical defined: The average residential customer uses 700 units of water per month. The water service charge is the only variable rate for a residential customer. All other fees are a fixed monthly fee.

# RATES FOR TRASH COLLECTION ADJUSTED

Submitted by Community Development

The City of Florence hired a consultant (Bell and Associates) to review the rates charged by Florence's two trash haulers: Central Coast Disposal and County Transfer and Recycling. The process included a two-and-a-half month study by Bell and Associates that involved standardizing the haulers financial and operating reporting and working with the city's Environmental Management Advisory Committee (EMAC). The study and its report were funded by local haulers. Bell and Associates found that the rates the City allows the haulers to charge customers within city limits do not allow them to reach even a 1% profit margin. Therefore, EMAC made new rate recommendations to the Florence City Council. The Council then passed Resolution No. 5 Series 2012, which approved a trash hauling rate increase that will be phased in over three years. Both EMAC and the council held public hearings before making its decision. A full rate review will be done again in 2015.

The staff report to Council and full rate schedule is available on the city's website at [http://www.ci.florence.or.us/sites/default/files/fileattachments/5\\_-\\_garbage\\_rate\\_adj..pdf](http://www.ci.florence.or.us/sites/default/files/fileattachments/5_-_garbage_rate_adj..pdf) The following table shows the rates that will be charged for basic residential curbside collection starting on July 1.

## **Basic Residential Curbside Service – Voluntary Yard Debris:**

The rates in this section include collection charges for garbage and recycling. **Voluntary yard debris collection, when available, is negotiated by the hauler.** These rates are for curbside service only. The customer places the container(s) at the curbside for collection and the customer retrieves the container after collection.

<b>Basic Residential Curbside</b>			
<b>RATE PER MONTH</b>			
	<b>Monthly<sup>1</sup></b>	<b>Every Other Week</b>	<b>Weekly</b>
21 Gallon or Less <sup>1,2</sup>	8.75	12.10	16.85
30-32 Gallon <sup>1,3</sup>	9.75	13.40	18.10
32-35 Gallon <sup>4</sup>	Not Available	15.85	21.75
48 Gallon	Not Available	17.45	24.15
60-65 Gallon	Not Available	18.75	26.35
90-95 Gallon	Not Available	24.05	34.60
<sup>1</sup> Only available for non-putrescible (non-food) solid waste			
<sup>2</sup> Rate applies to capacity of 21 gallons or less in a customer provided container			
<sup>3</sup> Rate applies to a capacity of 30-32 gallons in a customer provided container			
<sup>4</sup> Rate applies to a capacity of 32-35 gallons in a hauler provided container			





From left to right: Councilor Brian Jagoe, Council President Nola Xavier, Mayor Phil Brubaker, Council Vice-President Suzanne Roberts, Councilor Paul Holman

Visit the City of Florence online at [www.ci.florence.or.us](http://www.ci.florence.or.us)

City E-mail Addresses

Mayor Phil Brubaker  
phil.brubaker@ci.florence.or.us

Council President Nola Xavier  
nola.xavier@ci.florence.or.us

Council Vice President  
Suzanne Roberts  
suzanne.roberts@ci.florence.or.us

Councilor Paul Holman  
paul@ci.florence.or.us

Councilor Brian Jagoe  
brian.jagoe@ci.florence.or.us

City Manager Jacque Betz  
jacque.betz@ci.florence.or.us

City Recorder Kelli Weese  
kelli.weese@ci.florence.or.us

Public Works Director  
Mike Miller  
mike.miller@ci.florence.or.us

Community Development  
Director Sandra Belson  
sandra.belson@ci.florence.or.us

Finance Director  
Erin Reynolds  
erin.reynolds@ci.florence.or.us

Florence Events Center  
Director Kevin Rhodes  
kevin@eventcenter.org

Police Chief Ray Gutierrez  
ray.gutierrez@ci.florence.or.us

# MISSION STATEMENT

The mission of the City of Florence is to meet community expectations for municipal services, provide a vision for civic improvements, maintain a quality environment and position Florence to have an economically viable and sustainable future.

## City Calendar

For more information about meetings (days marked in yellow), contact City Hall at 541-997-3437.  
For information on events & concerts (days marked in blue), contact the Florence Events Center at 541-997-1994

# June 2012

Sun	Mon	Tue	Wed	Thu	Fri	Sat
					1	2
3	4 City Council Meeting 7:00 pm	5	6 City Hall Closed from 12 to 5 pm for training	7	8	9
10	11	12 Planning Commission Meeting 7:00 pm	13	14 Planning Commission Public Hearing 7:00 pm	15	16
17	18 City Council Worksession 6:30 pm Meeting 7:00 pm	19	20	21 EMAC 2:00 pm	22	23 Florence Indoor Yard Sale 8 am to 2 pm
24	25	26 Planning Commission Meeting 7:00 pm	27 FURA 6:30 pm	28	29	30 4th Annual Wings n Wheels Florence Airport